

# Wiring Diagram - EZGO PDS TXT 36V

Using TSX Harness Navitas PN: 40-000512

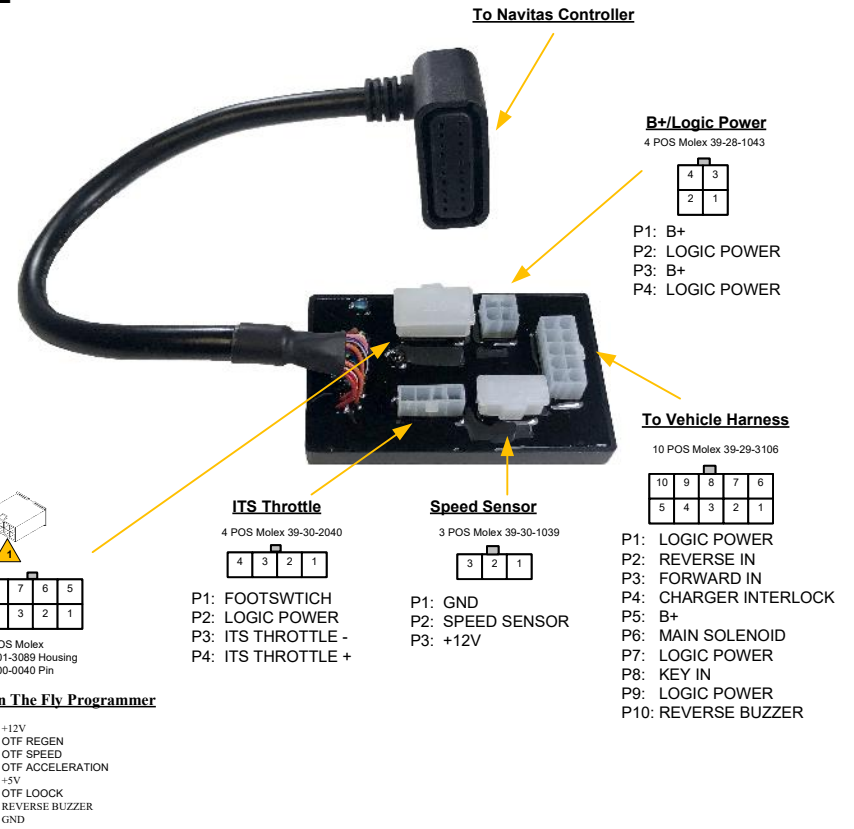

## Navitas TSX DC Shunt Controller

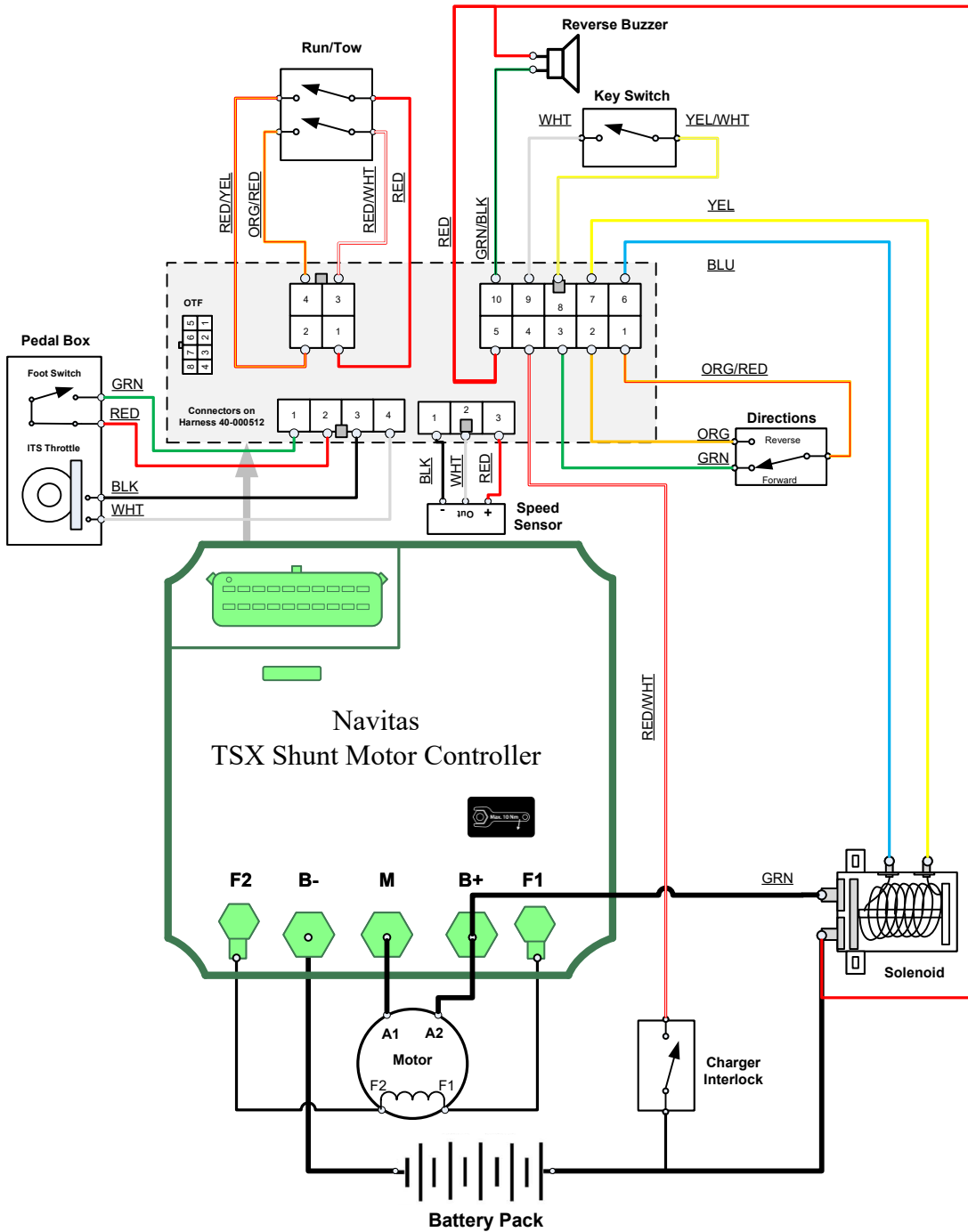
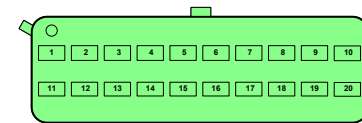

- P1: OTF LOCK
- P2: XCAN\_N
- P3: XCAN\_P
- P4: SPEED SENSOR SIGNAL
- P5: CHARGER INTERLOCK
- P6: REVERSE IN
- P7: FORWARD IN
- P8: KEY
- P9: GND
- P10: LOGIC POWER
- P11: +5V EXT
- P12: OTF ACCELERATION
- P13: OTF SPEED
- P14: OTF REGEN
- P15: THROTTLE IN
- P16: +12V POLY
- P17: FOOT SWITCH
- P18: GND POLY
- P19: REVERSE BUZZER
- P20: MAIN SOLENOID



## Revision History

- 20210308 Original
- 20250523 Correct Throttle Connector